

4 (a) State the principle of superposition.

.....
.....
..... [2]

(b) Light of wavelength $7.2 \times 10^{-7} \text{ m}$ is incident normally on a double slit, as shown in Fig. 4.1.

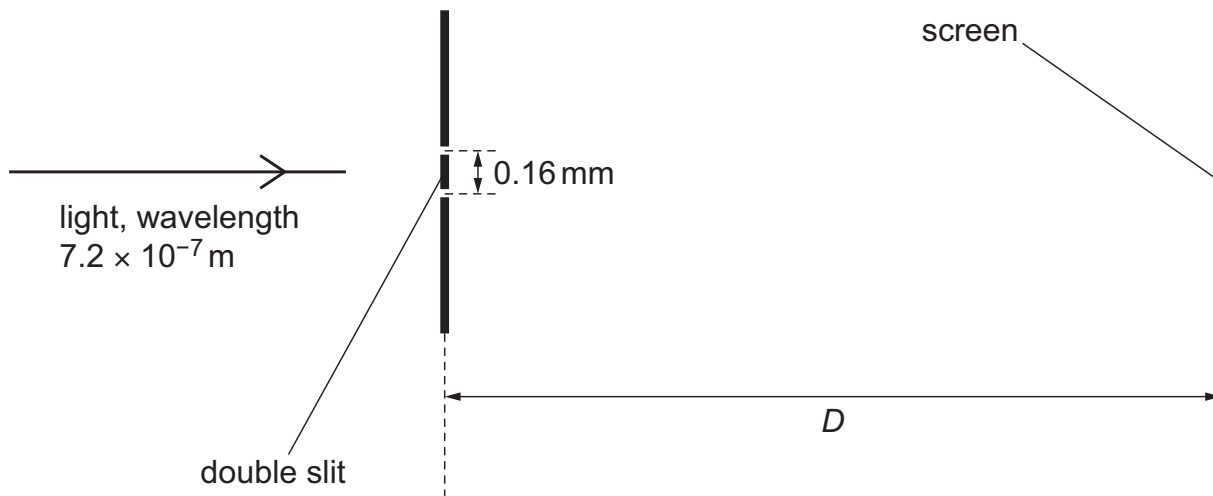

Fig. 4.1 (not to scale)

A screen is at a distance D from the double slit. The double slit and the screen are parallel.

The separation of the slits in the double-slit arrangement is 0.16 mm . The resulting interference pattern on the screen contains nine dark fringes, as shown in Fig. 4.2.

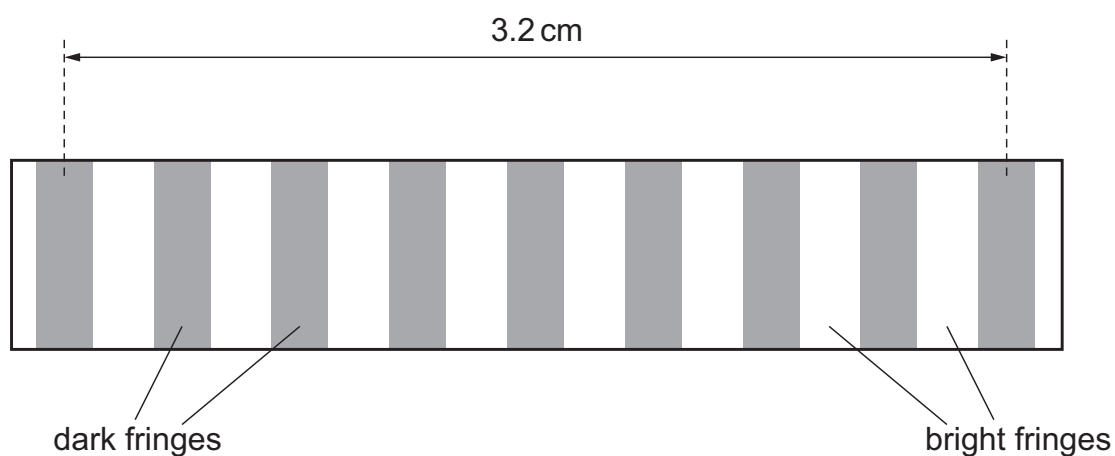

Fig. 4.2 (not to scale)

The distance between the centres of the first and ninth dark fringes is 3.2 cm .

(i) Calculate D .

$D = \dots\dots\dots \text{ m}$ [3]