

- 6 A nichrome wire X of length 45 cm and cross-sectional area $4.7 \times 10^{-7} \text{ m}^2$ is connected into the circuit shown in Fig. 6.1.

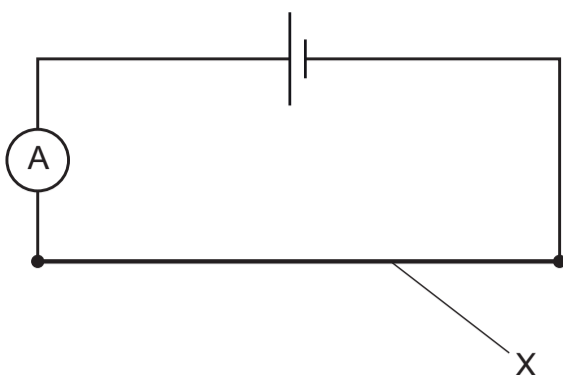

Fig. 6.1

The resistance of X is 1.1Ω . The cell has electromotive force (e.m.f.) 1.3 V and negligible internal resistance.

- (a) (i) Calculate the current in X.

current = A [1]

- (ii) The number density of charge carriers (electrons) in nichrome is $8.5 \times 10^{28} \text{ m}^{-3}$.

Calculate the average drift speed of the charge carriers in X.

average drift speed = ms^{-1} [2]

- (iii) Calculate the resistivity of the nichrome.

resistivity = $\Omega \text{ m}$ [3]

- (b) Wire Y is identical to wire X. Wire Y is added to the circuit in parallel with wire X, as shown in Fig. 6.2.

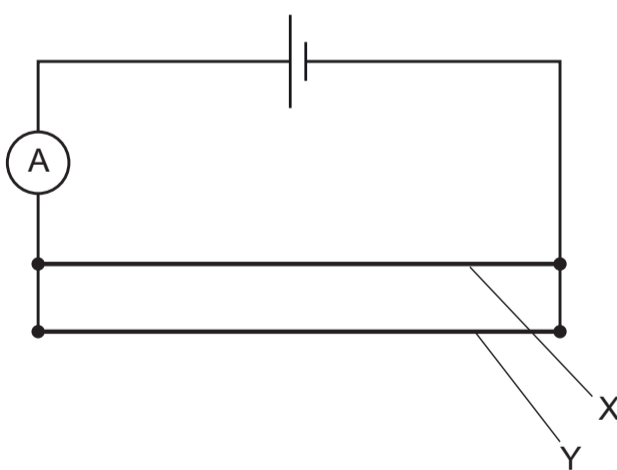

Fig. 6.2

State and explain the effect, if any, of this change on:

- (i) the reading on the ammeter

.....

 [2]

- (ii) the average drift speed of the charge carriers in X.

.....
 [1]