

1 (a) Define the moment of a force.

.....  
..... [1]

(b) A trapdoor has a hinge at end A, as shown in Fig. 1.1.

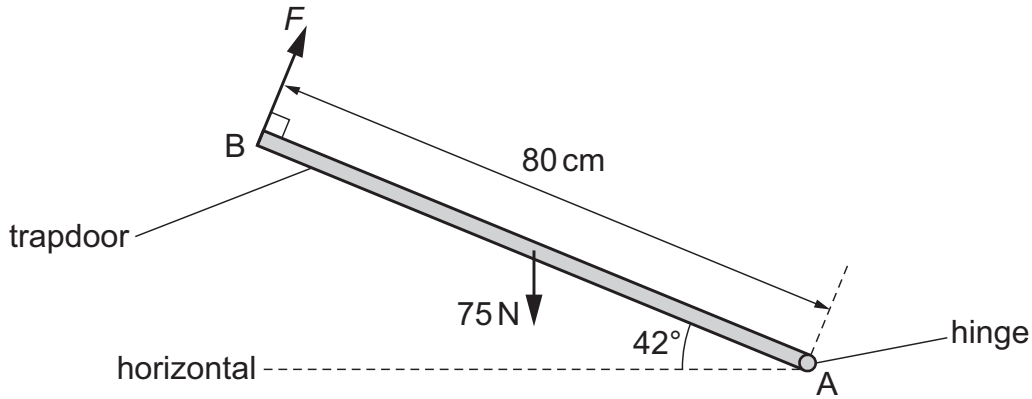

Fig. 1.1 (not to scale)

The trapdoor has length 80 cm and weight 75 N. The mass of the trapdoor is uniformly distributed along its length.

A force  $F$  acts at right angles to the trapdoor at end B so that the trapdoor is held in equilibrium at an angle of  $42^\circ$  to the horizontal.

(i) State the principle of moments.

.....  
.....  
..... [2]

(ii) Calculate the component of the weight that is perpendicular to the trapdoor.

component of weight = ..... N [1]

(iii) Calculate the magnitude of the force  $F$ .

$F =$  ..... N [2]

[Total: 6]