

6 A rectangular coil PQRS of wire is free to rotate about its axis XY, as shown in Fig. 6.1.

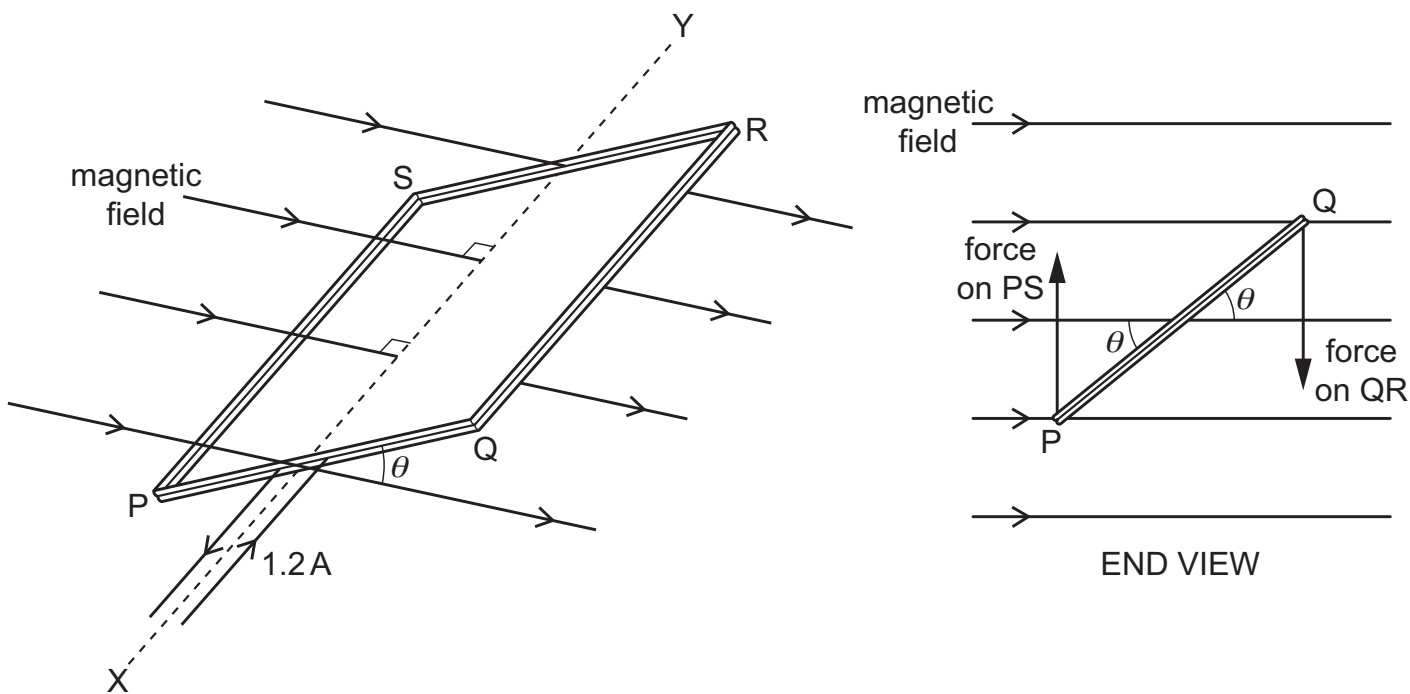

Fig. 6.1 (not to scale)

The coil has length QR of 5.4 cm, width PQ of 2.5 cm and has 190 turns of wire. The plane of the coil is at an angle θ to a uniform magnetic field of flux density 5.2×10^{-3} T. The axis XY of the coil is normal to the field. The current in the coil is 1.2 A.

(a) (i) Calculate the magnitude of the force on side QR of the coil.

force = N [3]

(ii) Use your answer in (a)(i) to show that the torque τ on the coil is given by

$$\tau = 1.6 \times 10^{-3} \cos \theta \text{ Nm.}$$

[2]

(iii) Using the expression in (a)(ii) sketch, on the axes of Fig. 6.2, a graph to show the variation of the torque τ with angle θ for values of θ between 0 and 360°. Label the τ axis with an appropriate scale.

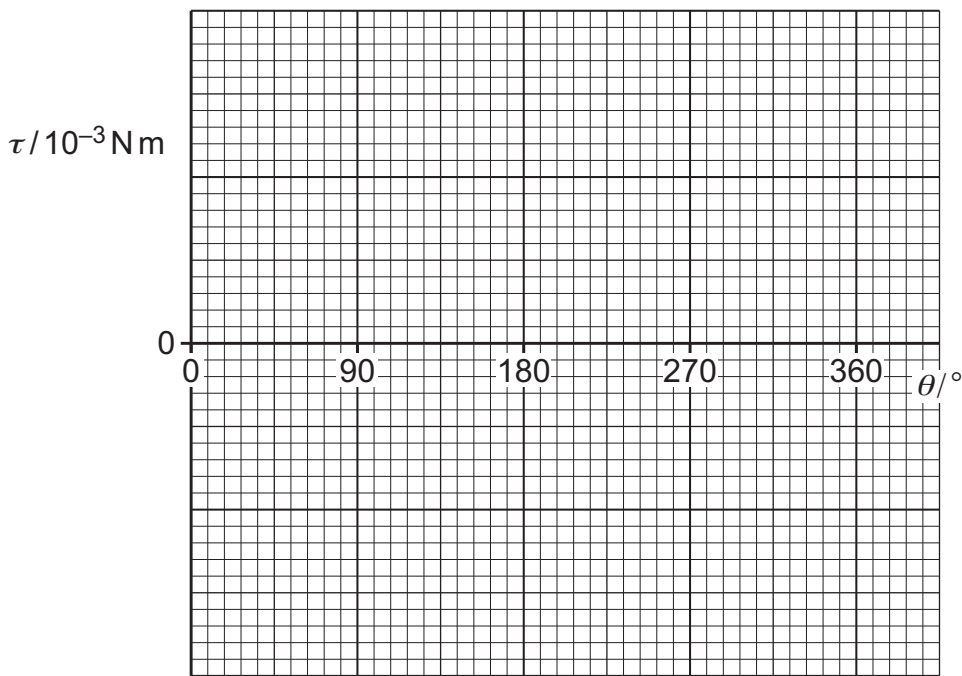

Fig. 6.2

[3]

(b) The coil is now replaced by an identical coil wound on a ferrous core.

Suggest, with a reason, how the torque on this coil compares with the torque on the original coil.

.....

[2]