

2 A student investigates an electrical circuit.

The circuit is set up as shown in Fig. 2.1.

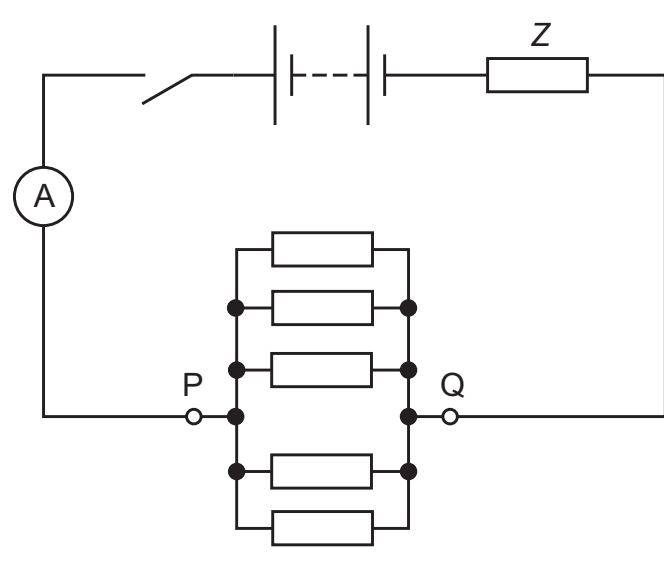

Fig. 2.1

A battery of negligible internal resistance is connected to a resistor of resistance Z . Five resistors, each of resistance R , are connected in parallel between P and Q.

The switch is closed. The total current I in the circuit is measured using the ammeter.

The experiment is then repeated by changing the number n of resistors, each of resistance R , connected in parallel between P and Q.

It is suggested that I and n are related by the equation

$$E = I \left(\frac{R}{n} + Z \right)$$

where E is the electromotive force (e.m.f.) of the battery.

(a) A graph is plotted of $\frac{1}{I}$ on the y-axis against $\frac{1}{n}$ on the x-axis.

Determine expressions for the gradient and y-intercept.

gradient =

y-intercept =

[1]

(b) Values of n , $\frac{1}{n}$ and I are given in Table 2.1.

Table 2.1

n	$\frac{1}{n}$	$I/\mu\text{A}$	$\frac{1}{I}/10^3\text{A}^{-1}$
5	0.200	455 ± 5	
6	0.167	525 ± 5	
7	0.143	580 ± 5	
8	0.125	635 ± 5	
9	0.111	685 ± 5	
11	0.0909	765 ± 5	

Calculate and record values of $\frac{1}{I}/10^3\text{A}^{-1}$ in Table 2.1. Include the absolute uncertainties in $\frac{1}{I}$.

[2]

(c) (i) Plot a graph of $\frac{1}{I}/10^3\text{A}^{-1}$ against $\frac{1}{n}$. Include error bars for $\frac{1}{I}$.

[2]

(ii) Draw the straight line of best fit and a worst acceptable straight line on your graph. Label both lines.

[2]

(iii) Determine the gradient of the line of best fit. Include the absolute uncertainty in your answer.

gradient = [2]

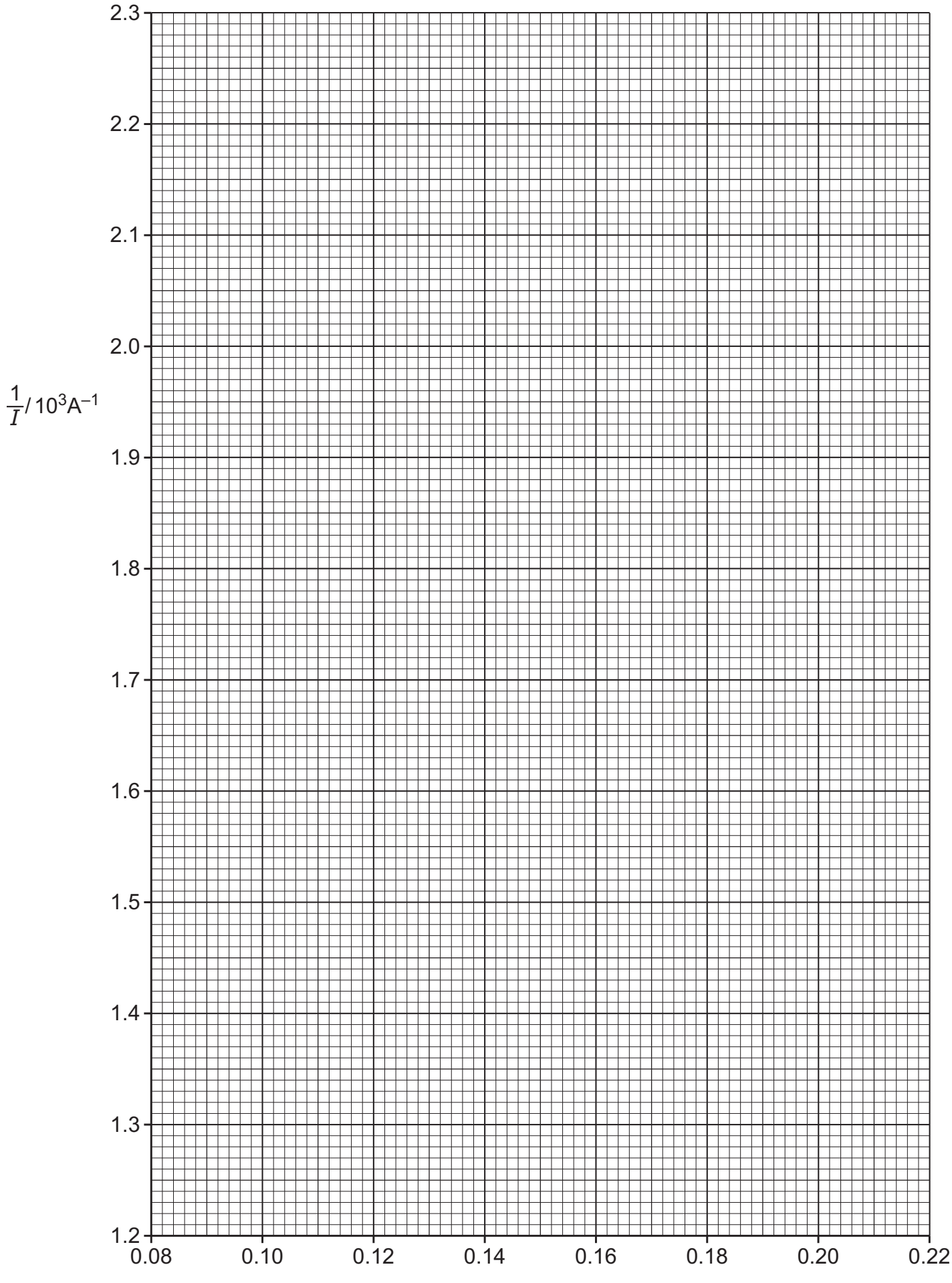

(iv) Determine the y-intercept of the line of best fit. Include the absolute uncertainty in your answer.

y-intercept = [2]

(d) The e.m.f. E of the battery is determined twice during the experiment. The values obtained are 5.6V and 6.0V.

(i) Using your answers to (a), (c)(iii) and (c)(iv), determine the values of R and Z . Include appropriate units.

$R =$

$Z =$

[2]

(ii) Determine the percentage uncertainty in your value of R .

percentage uncertainty = % [1]

(e) The experiment is repeated with 20 resistors, each of resistance R , connected in parallel between P and Q. Determine the total current I in the circuit.

$I =$ A [1]

[Total: 15]