

2 (a) State the principle of moments.

.....  
 .....  
 ..... [2]

(b) A solid plastic cylinder floats in water. It is used to support one end of a horizontal uniform beam AB as shown in Fig. 2.1.

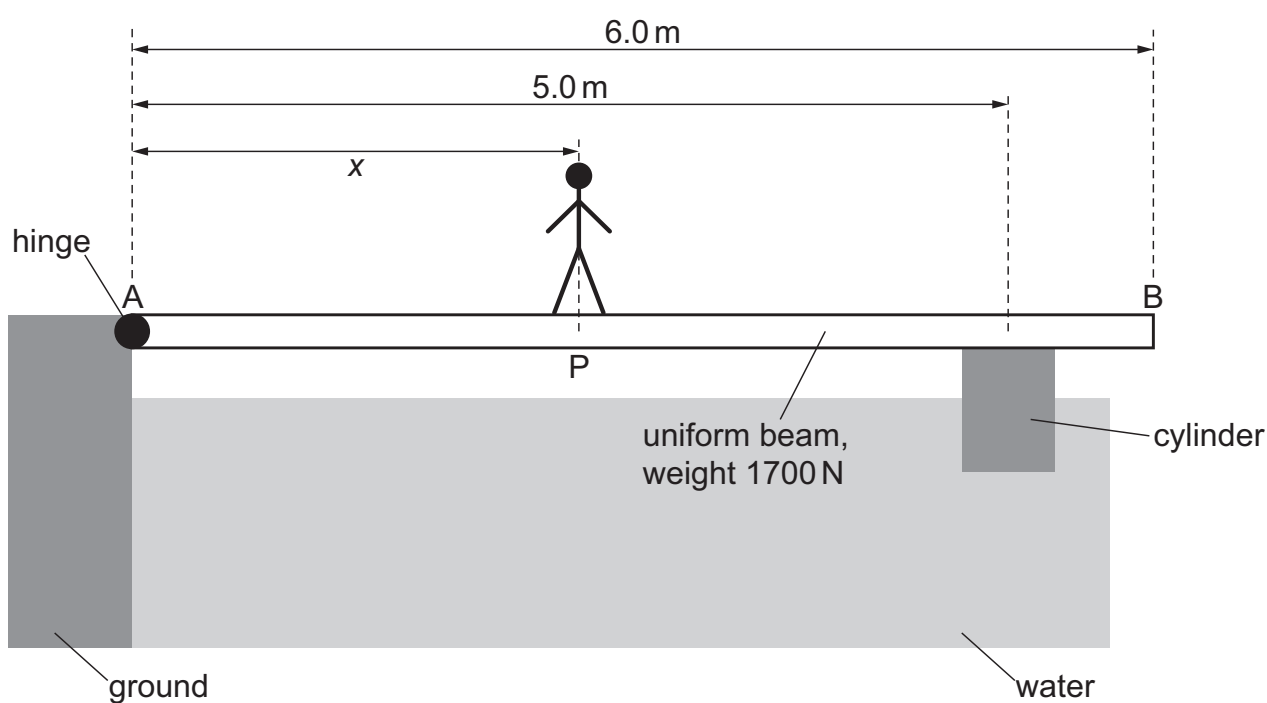

Fig. 2.1 (not to scale)

The beam has length 6.0 m and weight 1700 N. The beam is attached to solid ground with a hinge at end A.

The cylinder is floating vertically in the water. The top of the cylinder is attached at its centre to the beam at a horizontal distance of 5.0 m from end A. The cylinder applies a vertical force of 1300 N to the beam.

A person of weight 660 N stands on the beam at point P.

The beam AB is in equilibrium.

(i) By taking moments about end A, determine the distance  $x$  from A to P.

distance = ..... m [3]

(ii) The bottom of the cylinder is submerged in the water to depth  $y$  as shown in Fig. 2.2. The beam is still attached to the cylinder but not shown.

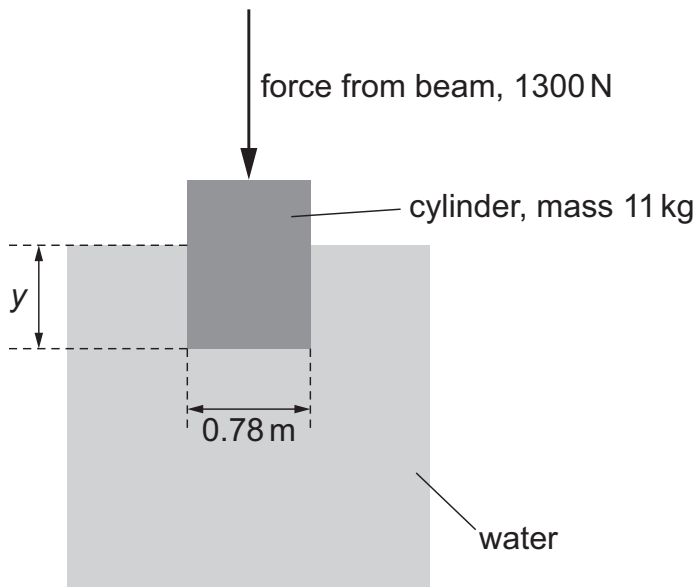

Fig. 2.2 (not to scale)

The cylinder has mass 11 kg and diameter 0.78 m. The beam exerts a vertical force of 1300 N on the cylinder. The cylinder is in equilibrium.

Show that the upthrust acting on the cylinder is 1400 N.

[1]

(iii) The water has density  $990 \text{ kg m}^{-3}$ .

Calculate the depth  $y$ .

$y = \dots\dots\dots$  m [2]