

- 3 (a) A truck R of mass 9400 kg moves with constant acceleration in a straight line down a slope, as illustrated in Fig. 3.1.

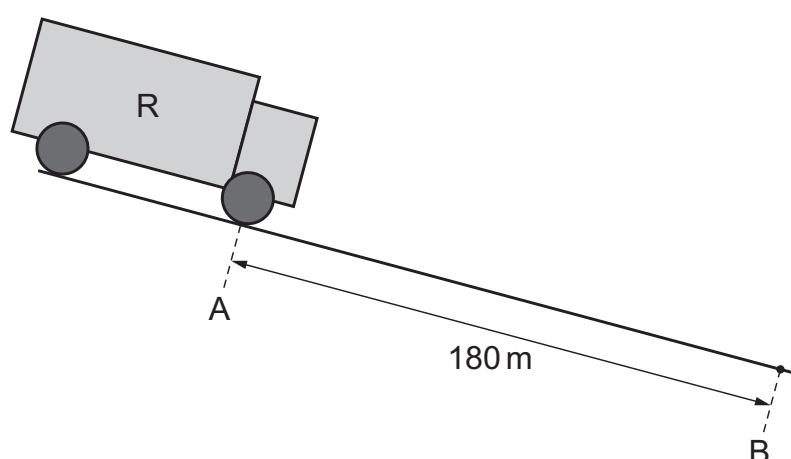

Fig. 3.1

At point A the speed of the truck is 13 ms^{-1} and at point B the speed of the truck is 22 ms^{-1} . A and B are a distance of 180 m apart.

- (i) Calculate the acceleration of the truck between A and B.

acceleration = ms^{-2} [2]

- (ii) Determine the gain in kinetic energy of the truck between A and B.

gain in kinetic energy = J [3]

- (b) A short time after passing point B truck R moves in a straight line on horizontal ground. The driver of the truck applies the brakes. Fig. 3.2 shows the variation with time of the momentum of the truck.

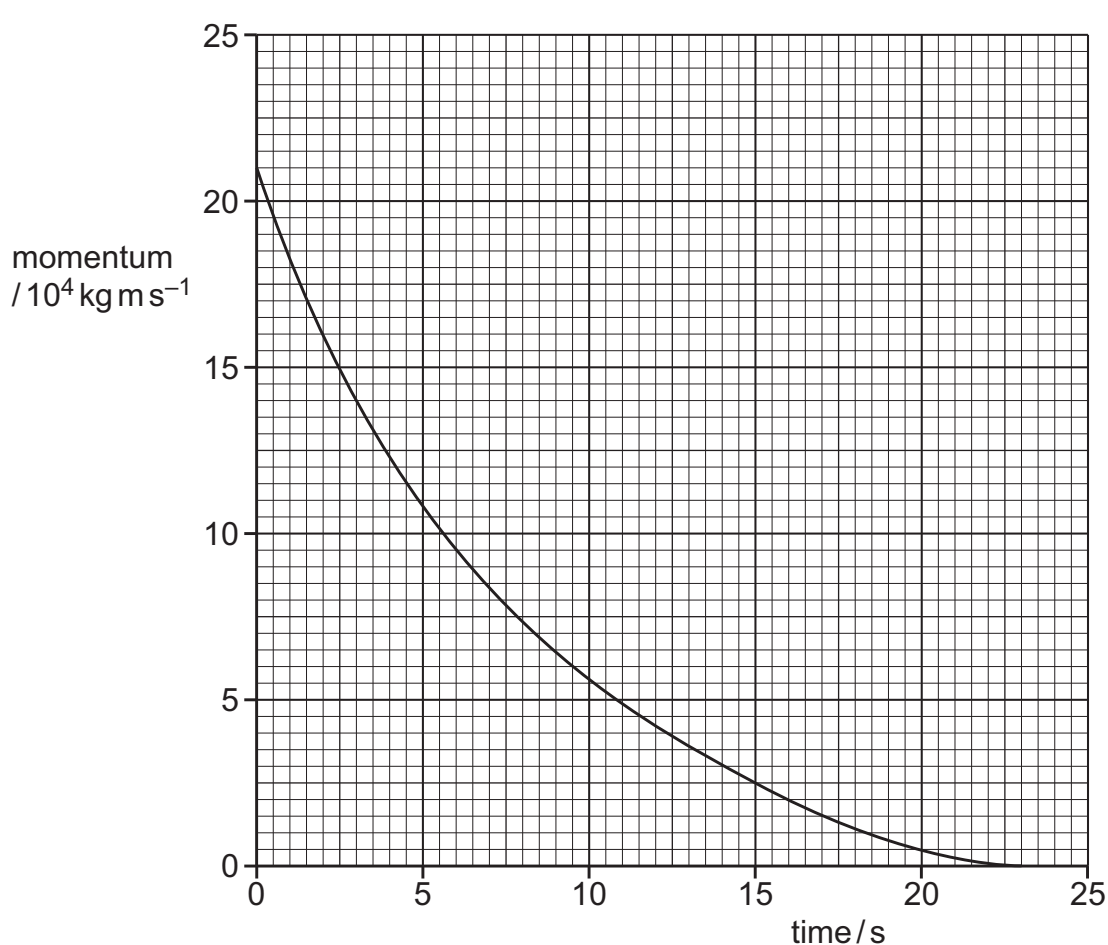

Fig. 3.2

- (i) Define force.

.....
 [1]

- (ii) Show that the average resultant force F acting on truck R between time $t = 0$ and $t = 15 \text{ s}$ is $-1.2 \times 10^4 \text{ N}$.

[1]

- (iii) An identical truck S has the same initial momentum as truck R. Truck S experiences a constant force equal to the force F in (b)(ii).

State and explain whether truck S will take more, less or the same amount of time to come to rest as truck R.

.....

 [3]