

- 5 (a) A capacitor of capacitance  $C_1$  is connected in series with a second capacitor of capacitance  $C_2$ .

Show that the combined capacitance  $C$  of the two capacitors is given by

$$\frac{1}{C} = \frac{1}{C_1} + \frac{1}{C_2}.$$

[2]

- (b) Three identical capacitors, each of capacitance  $C$ , are connected in a network as shown in Fig. 5.1.

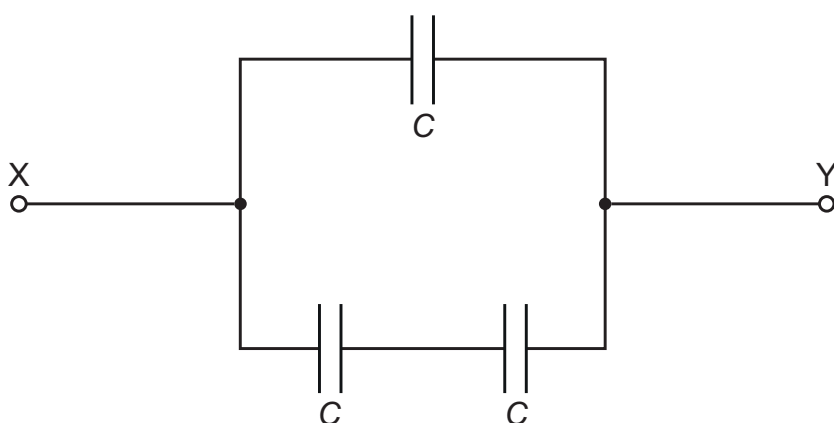

Fig. 5.1

The variation of the charge  $Q$  with the potential difference (p.d.)  $V$  between the terminals X and Y is shown in Fig. 5.2.

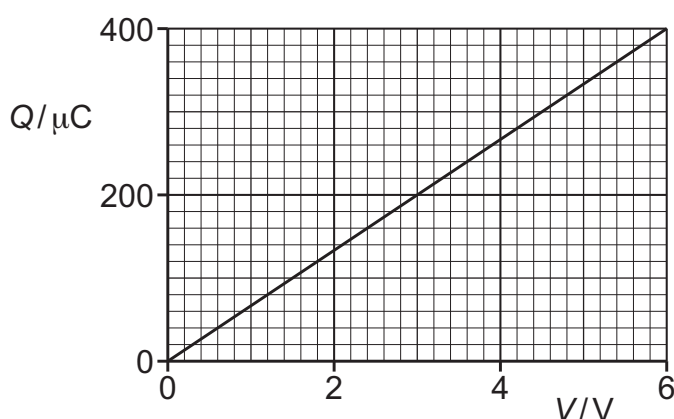

Fig. 5.2

Show that  $C$  is equal to  $44\ \mu\text{F}$ .

[3]

- (c) The capacitor network in Fig. 5.1 is charged and then connected to a resistor of resistance  $54\ \text{k}\Omega$ . The capacitor network discharges through the resistor.

- (i) Determine the time constant  $\tau$  of the circuit. Give a unit with your answer.

$\tau = \dots\dots\dots$  unit  $\dots\dots\dots$  [2]

- (ii) Determine the time taken for the discharge current to reduce to 15% of the initial discharge current.

time =  $\dots\dots\dots$  s [2]

[Total: 9]