

- 2 Fig. 2.1 shows a square metal sheet of non-uniform density, with a thin wooden rod fixed at its centre. One of the corners of the sheet is labelled X.

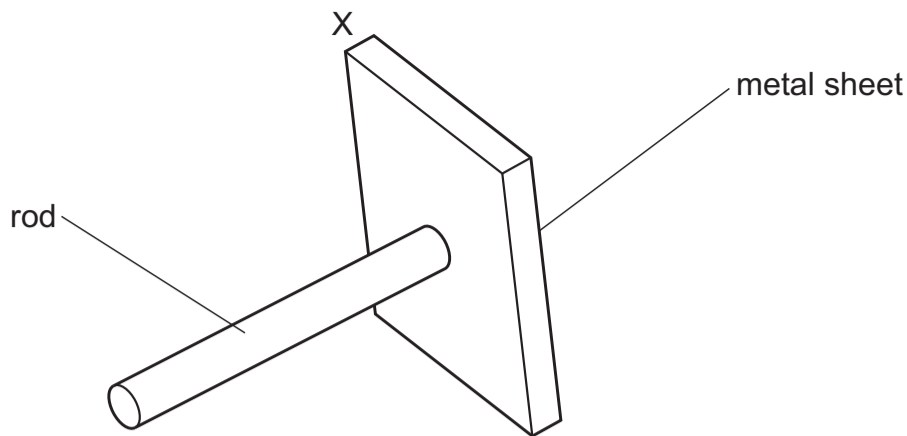

Fig. 2.1

The rod has negligible mass. The mass of the metal sheet is 2.8 kg. The rod is supported so that the rod is horizontal and the metal sheet is vertical.

- (a) Define the torque of a couple.

.....

 [2]

- (c) When a torque of 3.3 Nm is applied to the rod, the sheet is held in equilibrium with two of its edges horizontal, as shown in Fig. 2.3. Point X is at the top-left corner.

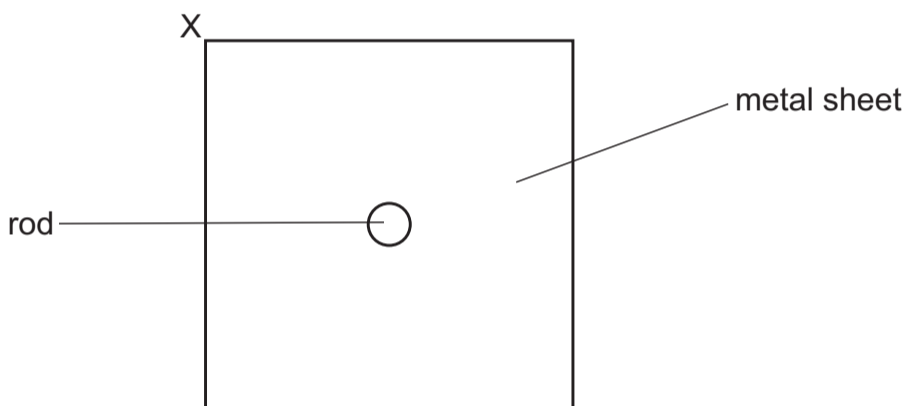

Fig. 2.3

- (i) Explain whether the torque applied to the rod to hold the sheet in equilibrium is clockwise or anticlockwise.

.....
 [1]

- (ii) Show that the centre of gravity of the sheet has a horizontal displacement of 0.12 m from the rod.

[1]

- (d) The square metal sheet has an average density of 3000 kg m^{-3} and a uniform thickness of 4.0 mm.

Show that the side length of the sheet is 0.48 m.

[3]

- (e) Use the answer in (b) and the information in (c) and (d) to determine the position of the centre of gravity of the sheet. Indicate this position on Fig. 2.3 with a point labelled Y. [2]

[Total: 10]