

1 In this experiment, you will investigate oscillations.

You have been provided with a double spring and two single springs.

- (a) (i) • Slide the double spring and the two single springs onto the longer wooden rod.
 • Set up the apparatus as shown in Fig. 1.1.

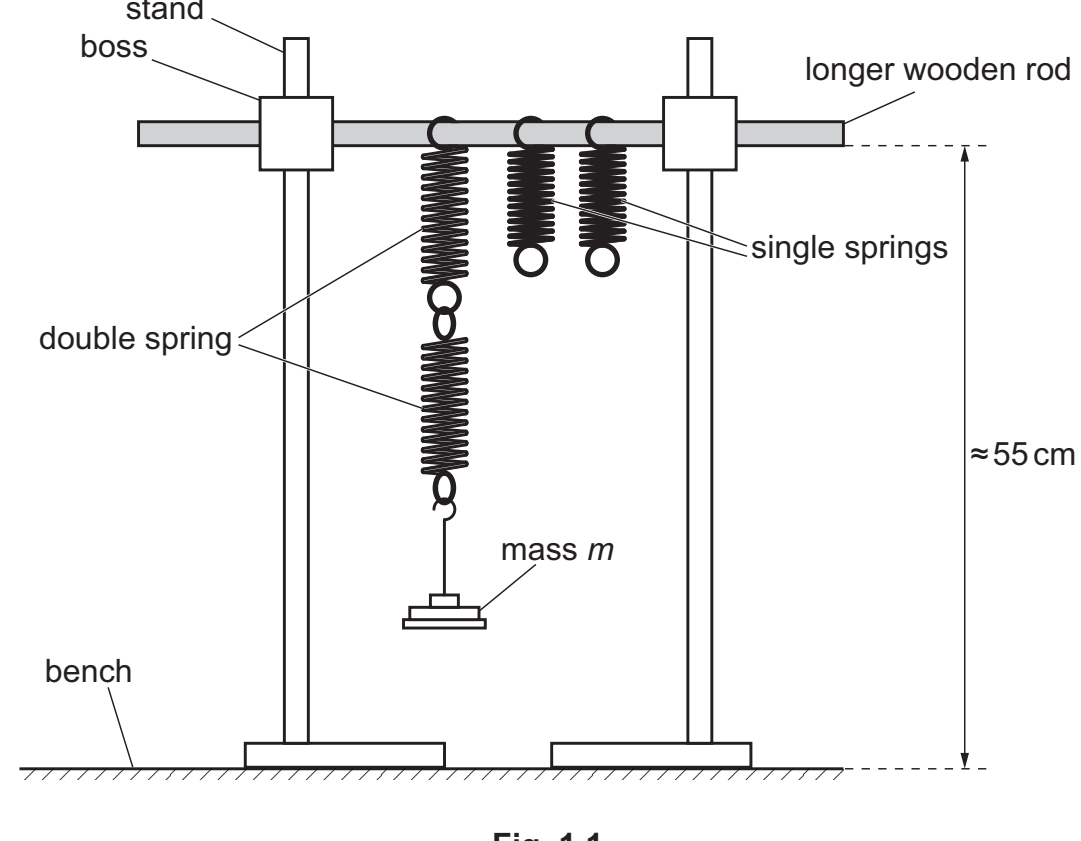

Fig. 1.1

- Use the bosses to fix the wooden rod approximately 55 cm above the bench and parallel to the bench.
- Hang a total mass of 270 g from the double spring.
- The mass hanging from the double spring is m .

Record m .

$m = \dots\dots\dots$ [1]

- (ii) • Gently pull the mass down through a short distance. When released, the mass will oscillate.
 • Take measurements to determine the period T_1 of the oscillations.

$T_1 = \dots\dots\dots$

- Remove the mass from the double spring.
- [2]

- (b) • Using the shorter wooden rod, hang mass m as shown in Fig. 1.2.

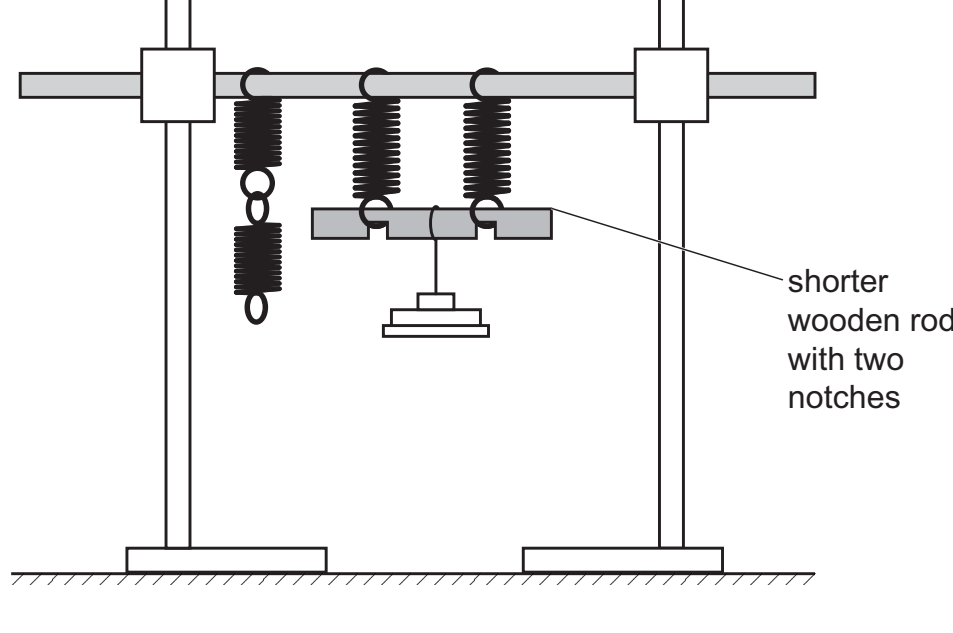

Fig. 1.2

- **Gently** place the hook of the mass hanger near the centre of the shorter rod.
- **Carefully** adjust the position of the mass hanger until the shorter rod is approximately parallel to the bench, as shown in Fig. 1.2.
- Gently pull the mass down through a short distance. When released, the mass will oscillate.
- Take measurements to determine the period T_2 of the oscillations.

$T_2 = \dots\dots\dots$

- Remove the mass.
- [1]

- (c) Vary m . For each value of m , determine T_1 and T_2 . Repeat until you have five sets of values of m , T_1 and T_2 . Do **not** use values of m less than 200 g.

Record your results in a table. Include values of $\sqrt{T_1}$ and $\sqrt{T_2}$ in your table.

[8]

- (iii) Determine the gradient and y-intercept of this line.

gradient = $\dots\dots\dots$

y-intercept = $\dots\dots\dots$

[2]

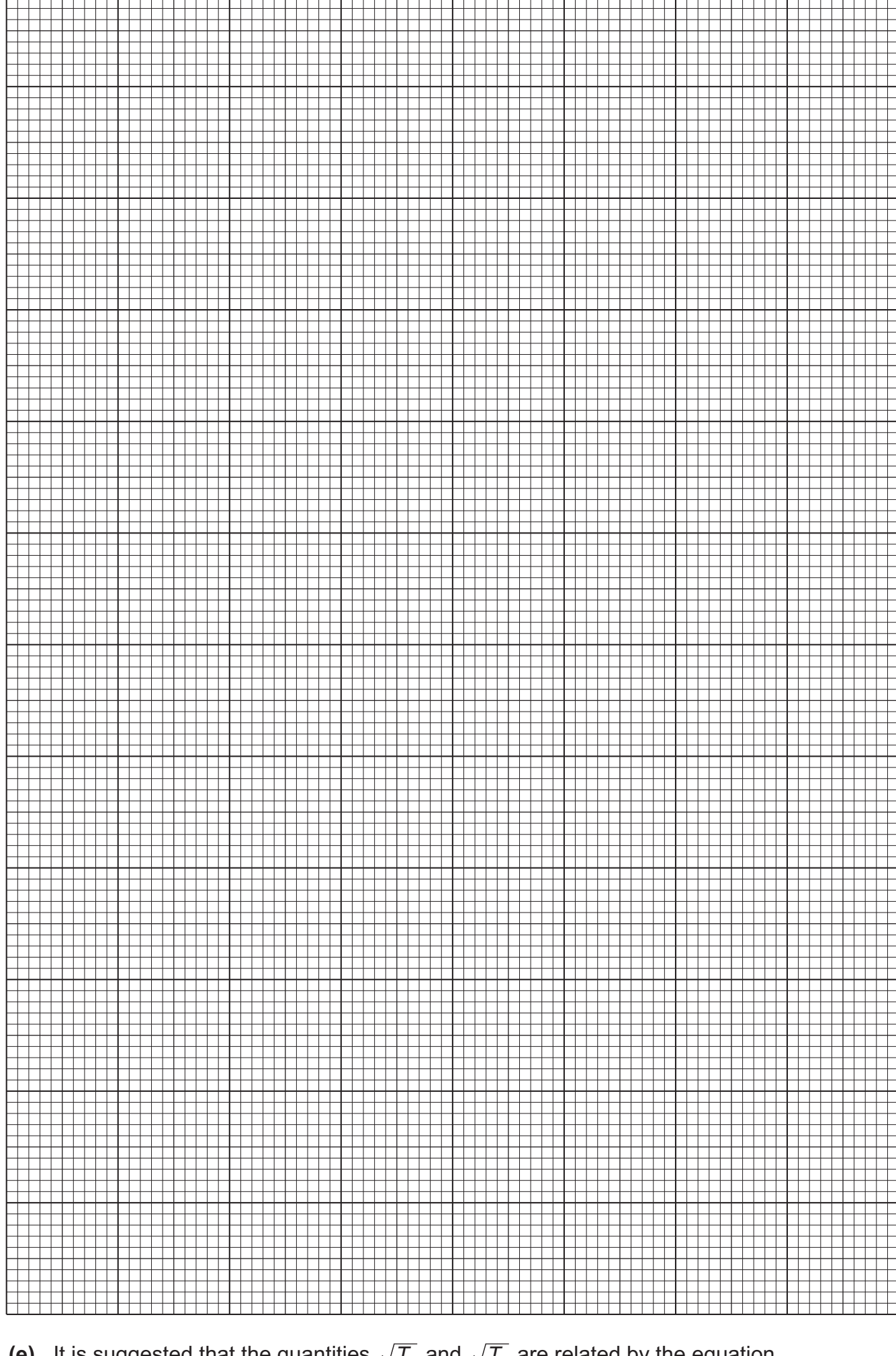

- (e) It is suggested that the quantities $\sqrt{T_2}$ and $\sqrt{T_1}$ are related by the equation

$$\sqrt{T_2} = P\sqrt{T_1} + Q$$

where P and Q are constants.

Using your answers in (d)(iii), determine the values of P and Q . Give appropriate units.

$P = \dots\dots\dots$

$Q = \dots\dots\dots$

[2]

[Total: 20]

You may not need to use all of the materials provided.