

1 In this experiment, you will investigate the equilibrium of forces.

- (a) (i) • Assemble the apparatus as shown in Fig. 1.1.

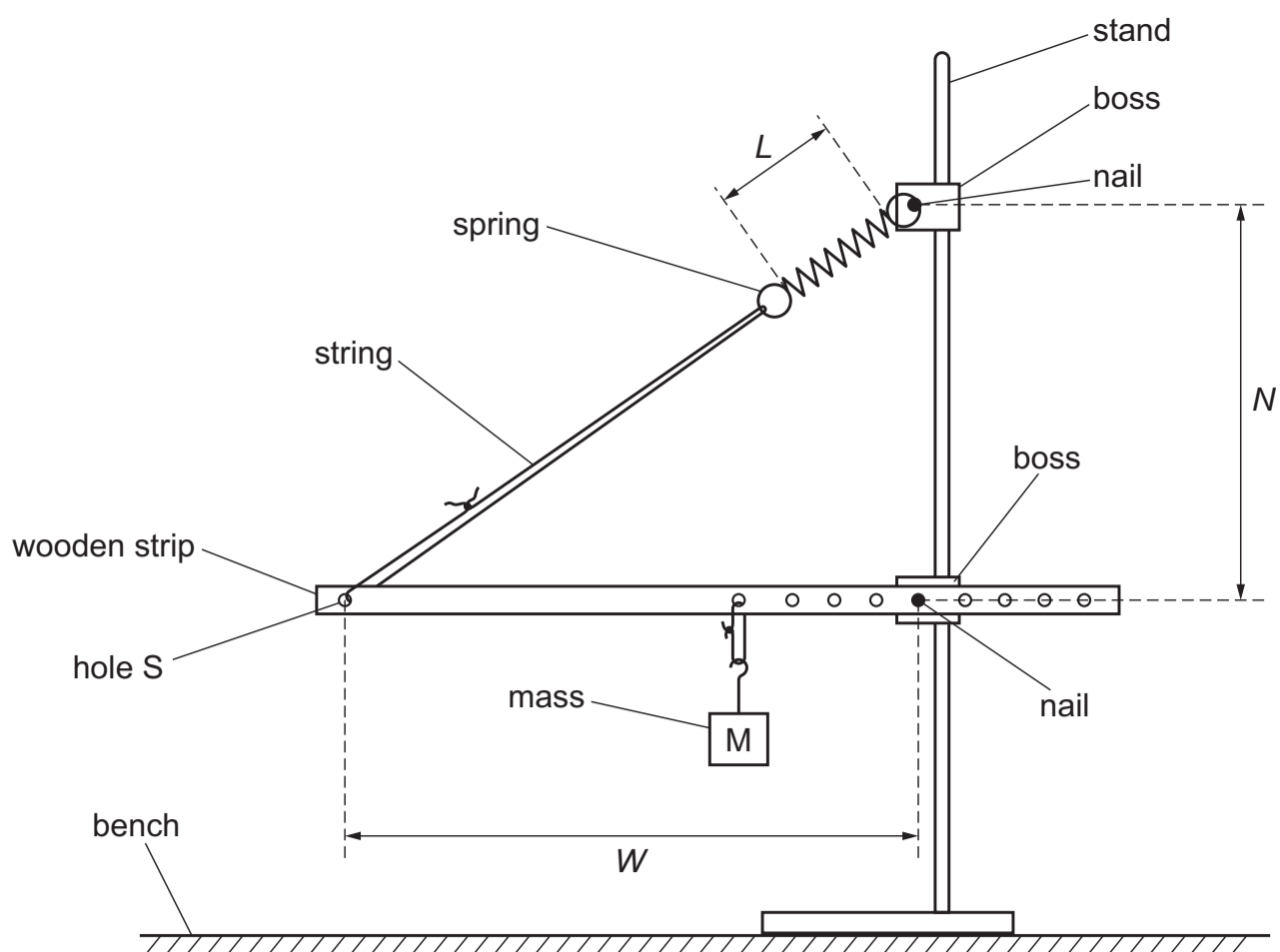

Fig. 1.1

- Adjust the height of the upper boss so that the wooden strip is parallel to the bench.
- The distance between hole S and the lower nail is  $W$ .

Measure and record  $W$ .

$W = \dots\dots\dots$

- The distance between the two nails is  $N$ .

Measure and record  $N$ .

$N = \dots\dots\dots$

- The length of the coiled part of the spring is  $L$ , as shown in Fig. 1.1.

Measure and record  $L$ .

$L = \dots\dots\dots$

[3]

- (ii) Calculate  $Z$ , where

$$Z = \frac{W}{\sqrt{(N^2 + W^2)}}$$

$Z = \dots\dots\dots$  [1]

- (b) Change  $W$  by moving the lower nail to another hole in the wooden strip. Adjust the height of the upper boss so that the wooden strip is parallel to the bench.

Measure and record  $W$ ,  $N$  and  $L$ . Repeat until you have six sets of values. Record your results in a table. Include values of  $Z$  in your table.

[8]

- (iii) Determine the gradient and  $y$ -intercept of this line.

gradient =  $\dots\dots\dots$

$y$ -intercept =  $\dots\dots\dots$

[2]

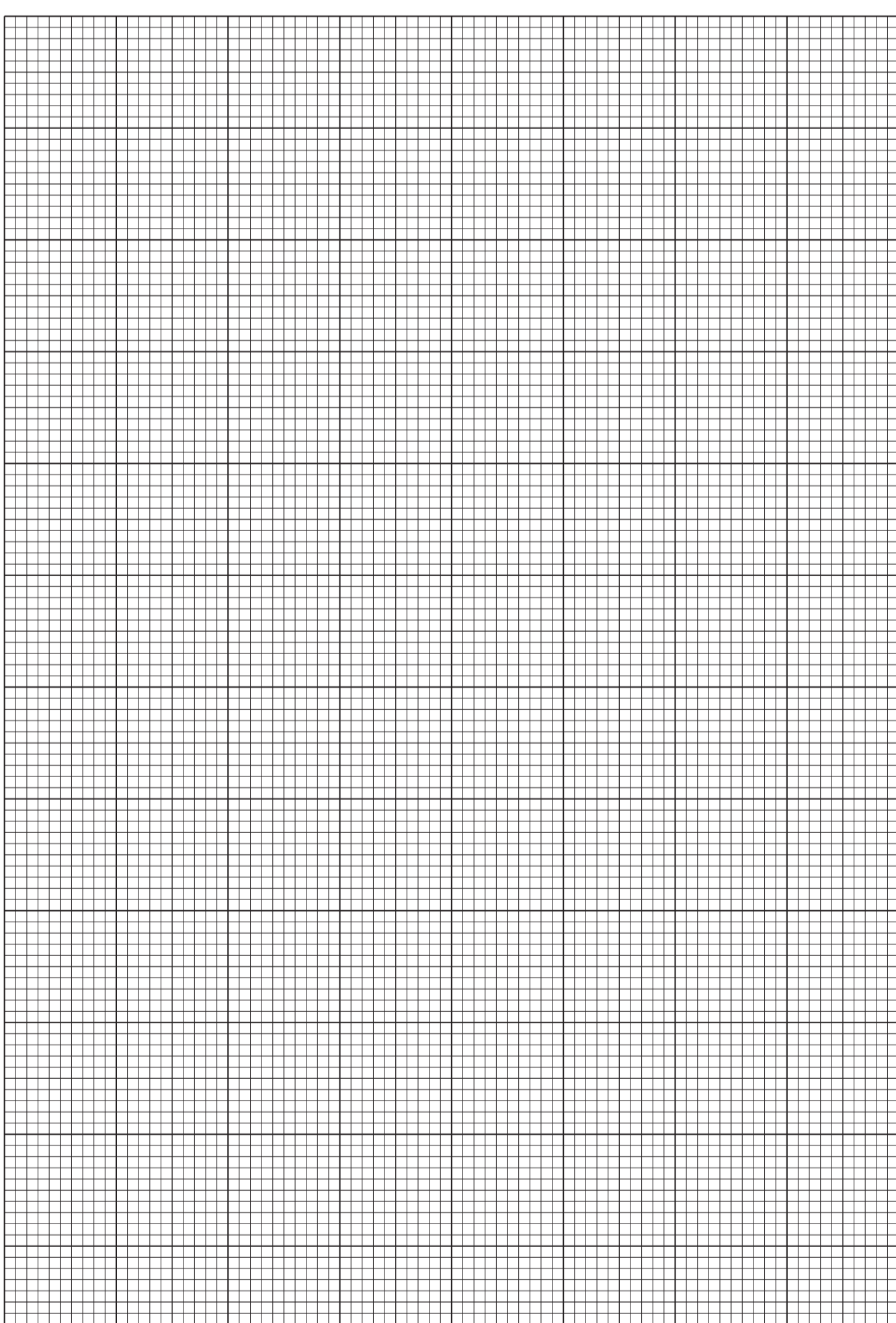

- (d) It is suggested that the quantities  $L$  and  $Z$  are related by the equation

$$L = aZ + b$$

where  $a$  and  $b$  are constants.

Use your answers in (c)(iii) to determine the values of  $a$  and  $b$ .

Give appropriate units.

$a = \dots\dots\dots$

$b = \dots\dots\dots$

[2]

[Total: 20]

You may not need to use all of the materials provided.