

1 A student investigates the stretching of a spring.

Fig. 1.1 shows the set-up.

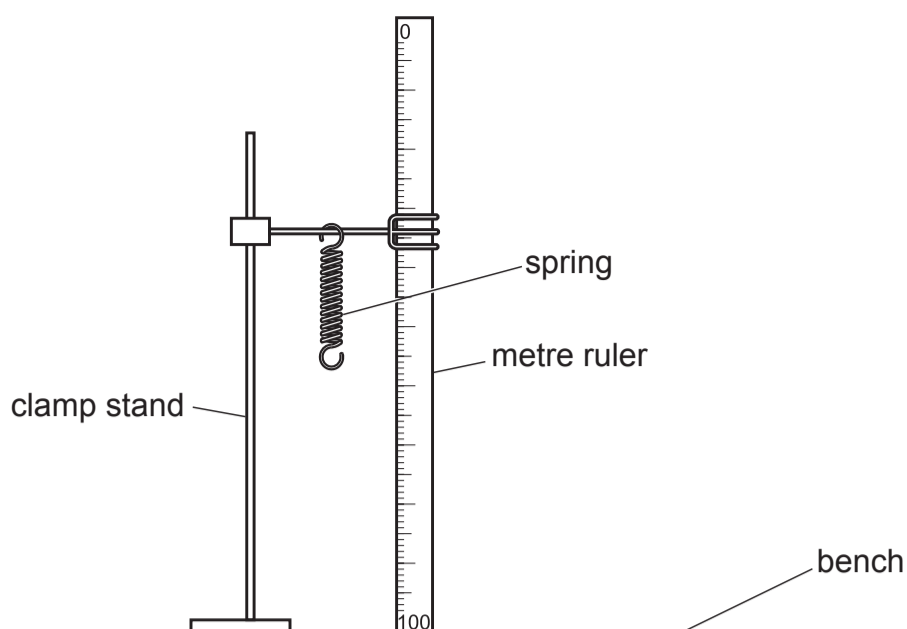

Fig. 1.1

(a) The student measures, and records in Table 1.1, the unstretched length l_0 of the spring. He does **not** include the loops at the ends of the spring in the measurement. The value l_0 is the length of the spring when the load L on the spring is 0.00 N.

Describe **one** technique you would use to obtain an accurate value for l_0 . Draw a diagram to illustrate your answer.

.....

 [2]

(b) The student suspends a load $L = 1.00$ N from the spring. He records the new length l of the spring in Table 1.1.

He calculates the extension e of the spring using the equation $e = (l - l_0)$ and records the value of e in Table 1.1.

The student repeats the procedure using loads $L = 2.00$ N, 3.00 N, 4.00 N and 5.00 N. The readings and results are recorded in Table 1.1.

Calculate the extension e of the spring using the equation $e = (l - l_0)$ when $L = 5.00$ N. Record this value of e in Table 1.1.

Table 1.1

L /N	l /cm	e /cm
0.00	2.1	0.0
1.00	6.0	3.9
2.00	10.6	8.5
3.00	14.9	12.8
4.00	19.3	17.2
5.00	23.7	

[1]

(c) Plot a graph of L /N (y -axis) against e /cm (x -axis). Start both axes at the origin (0, 0). Draw the best-fit line.

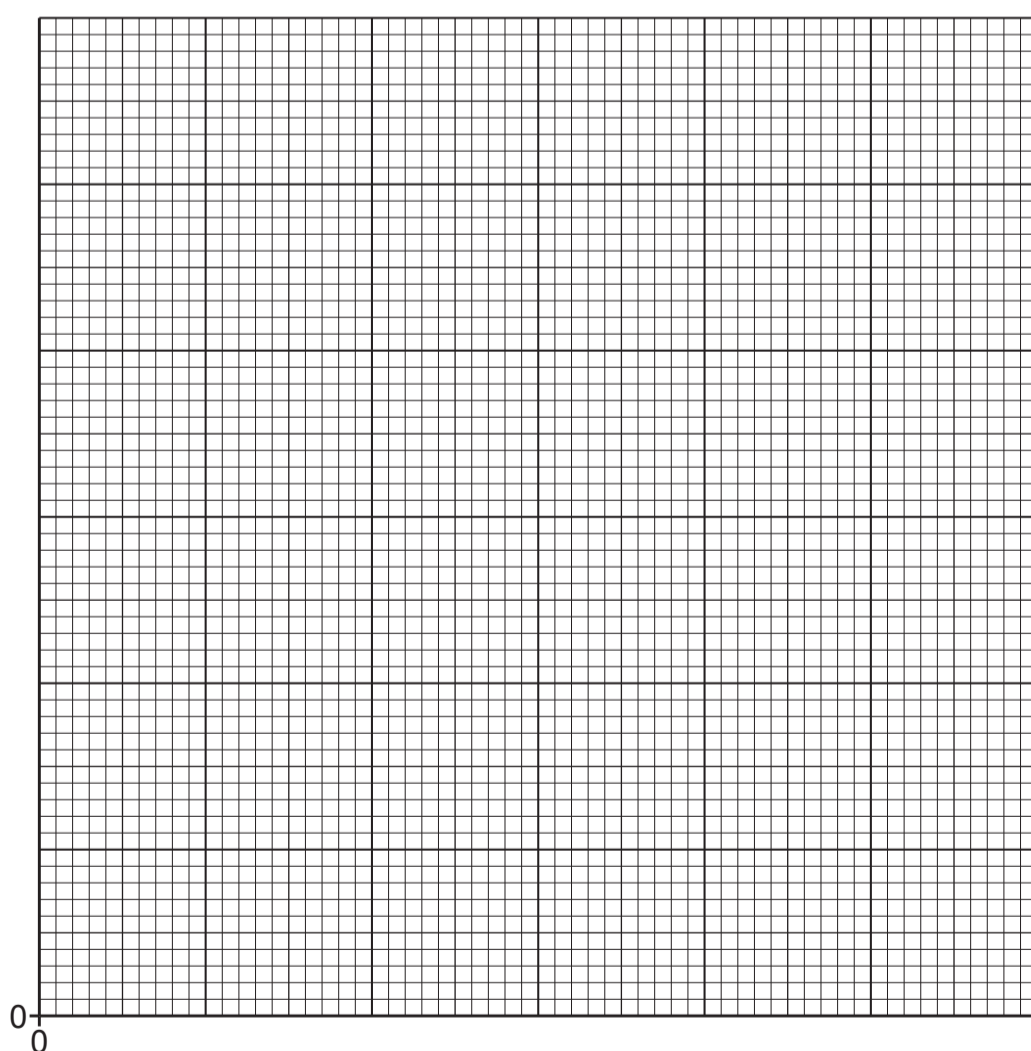

[4]

(d) Determine the gradient G of the graph. Show all your working and indicate on the graph the values you use.

$G =$ [2]

(e) G is numerically equal to the spring constant k .

Record the value of k to a suitable number of significant figures for this experiment. Include the unit.

$k =$ [2]

[Total: 11]