

- 5 A ray of light is incident on a soap film. Fig. 5.1 shows a magnified image of a small part of the soap film. The ray of light is refracted as it enters the soap film.

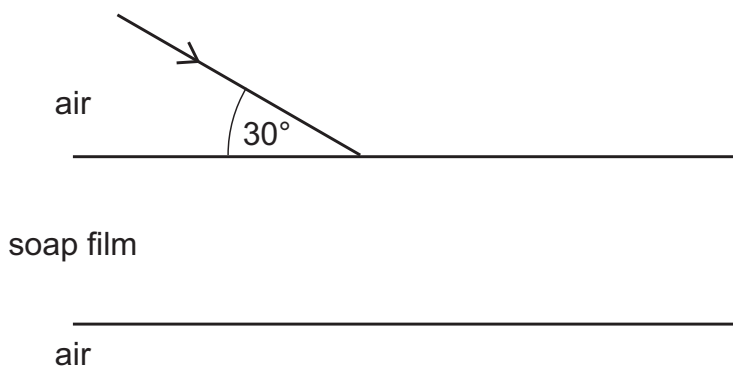

Fig. 5.1

The refractive index of the soap film is 1.28.

- (a) Define refractive index in terms of the speed of light.

.....
 [1]

- (b) (i) Show that the angle of refraction as the light enters the soap film is approximately 43° .

[2]

- (ii) On Fig. 5.1, carefully draw the refracted light ray in the soap film and label the angle of refraction. [2]

- (c) The ray of light is monochromatic red light with a wavelength of 680 nm in air.

- (i) Define monochromatic.

.....
 [1]

- (ii) Calculate the frequency of the light.

frequency = [3]